

Stromag Periflex® TT Top Torque Shaft Coupling

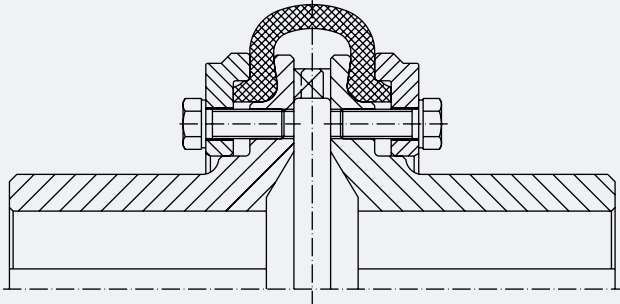
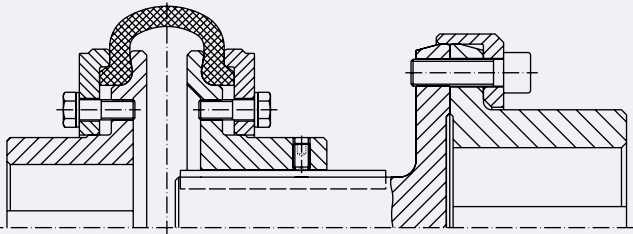
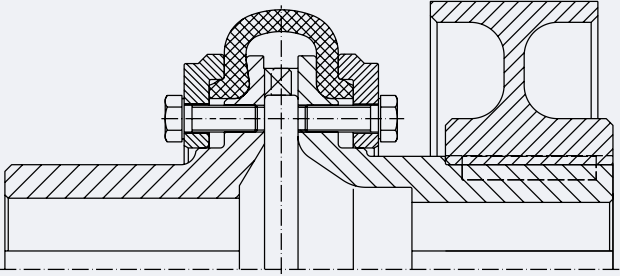
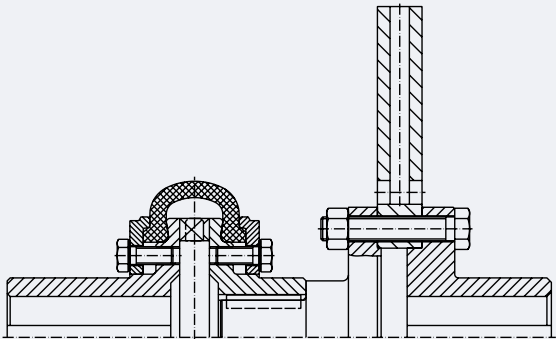

Stromag Periflex® Top Torque-Shaft Coupling

Further shaft coupling variants

<p>PNC</p> <p>Shaft coupling with fail-save device</p> <p>Nominal torque range 35 – 15,000 Nm</p>	 A technical cross-section drawing of a shaft coupling. It shows two shafts connected by a central coupling element. A fail-save device, consisting of a curved, textured component, is mounted on top of the coupling, secured with bolts. The shafts are supported by bearings within a housing.
<p>PNP</p> <p>Shaft coupling with dismantling part (SPN/SPL) for pump drives</p> <p>Nominal torque range 35 – 1600 Nm</p>	 A technical cross-section drawing of a shaft coupling. It features a central coupling element between two shafts. A dismantling part, which is a curved, textured component, is positioned on top of the coupling. The assembly is supported by bearings and a housing.
<p>PNB</p> <p>Shaft coupling with brake drum</p> <p>Nominal torque range 300 – 10,000 Nm</p>	 A technical cross-section drawing of a shaft coupling. It shows two shafts connected by a central coupling element. A brake drum is mounted on the right shaft. The coupling is supported by bearings and a housing.
<p>PND</p> <p>Shaft coupling with brake drum</p> <p>Nominal torque from 300 – 10,000 Nm</p>	 A technical cross-section drawing of a shaft coupling. It shows two shafts connected by a central coupling element. A brake drum is mounted on the right shaft. The coupling is supported by bearings and a housing.

Stromag Periflex® Top Torque-Shaft Coupling

All issues containing details on Stromag Periflex® Top Torque prior to this publication may no longer apply.

We reserve the right to modify the dimensions and constructions.

Stromag products comply with the Quality Standard to DIN ISO 9001.

Content	Page
Stromag Periflex® Top Torque concept	4
Instructions for the designer	
• Use in potentially explosive environments	5
• Classification rules	
Instructions on choosing the coupling size	
• Application factor	6
Assembly instructions and scope of delivery	7
Storing flexible rubber elements	7
Assignment of Stromag Periflex® Top Torque coupling to electric motors	8
Output table, PTT with R tyres	10
Output table, PTT with X tyres	12
Series	14
• Stromag PTT	15
• Stromag PTS	16
Characteristics of Periflex® Top Torque	18
Coupling design, question sheet	22
Use in potentially explosive environments, question sheet	23

Stromag Periflex® Top Torque-Shaft Coupling

Stromag Periflex® Top Torque concept

The Stromag Periflex® Top Torque is a highly flexible rubber-fabric coupling. Particularly suitable for connecting two shafts in diesel engine and electric drives.

The series covers the torque range from 35 to 20,500 Nm. Due to the special design of the shaft tyre, the Periflex® Top Torque is able to absorb extremely large displacements in every direction with low restoring forces, without noticeable wear and tear. As standard, the tyre can be radially mounted and dismantled using a separation joint without moving the connected machines. The Periflex® Top torque transmits the torque absolutely free of backlash. It is suitable for absorbing torque shocks and dampens vibrations.

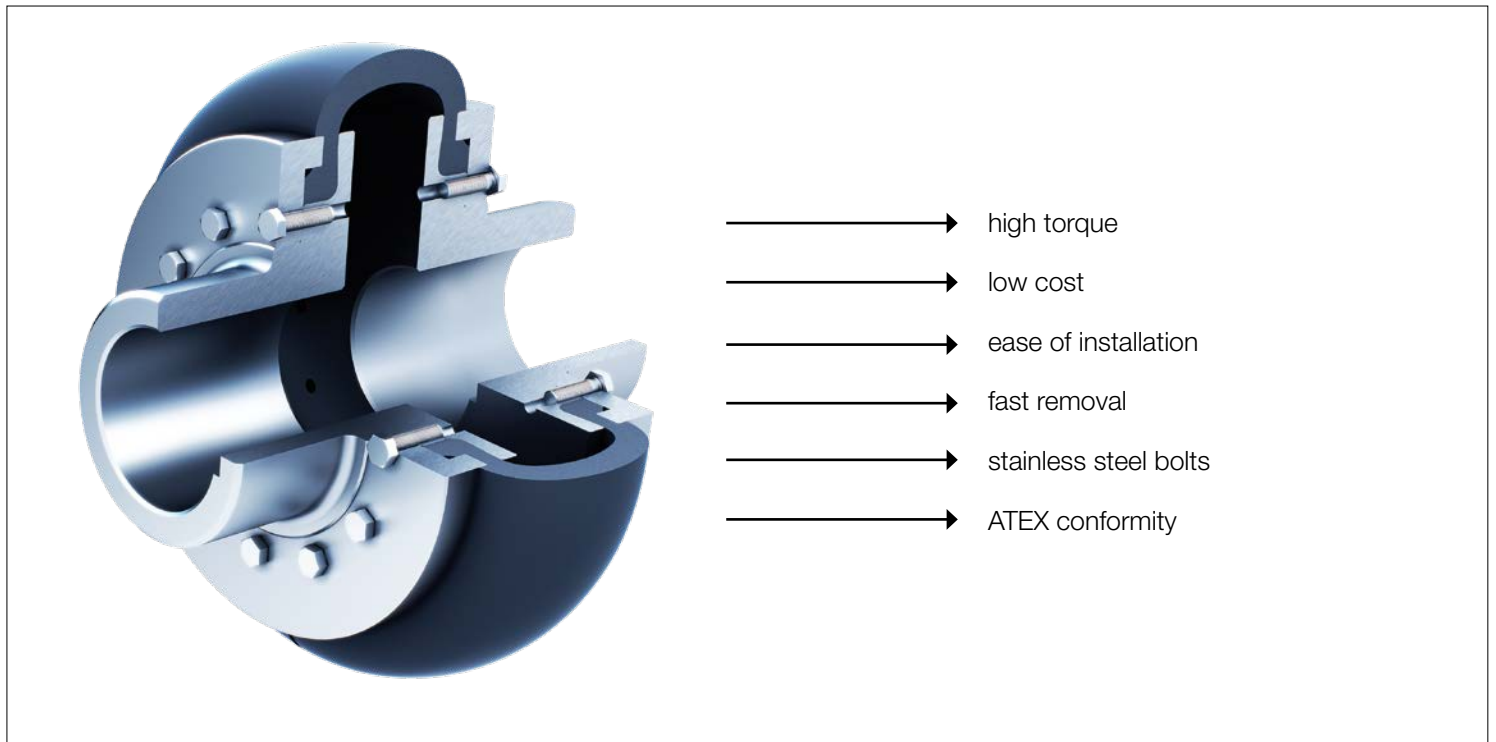

Application fields

The Periflex® Top Torque is especially suited for use in metallurgical plants, in crane construction as well as for roller table drives. Other areas of application include electrical power units, compressors, the construction machinery industry, crane construction and general mechanical engineering.

Instructions for the designer

The coupling hubs and pressure rings are made of steel and have a corrosion protection layer. The shaft tyre is made of natural rubber with fabric inserts. In the R-tyres, the fabrics are laid in radial alignment and in X-tyres they are diagonal. Different technical properties are achieved by changing the type of fabric arrangement.

The Stromag Periflex® Top Torque develops a certain axial force under the influence of torque and speed, which must be absorbed by suitable bearings. In order to determine the axial forces that occur, the Stromag technical document "Determining the resulting axial forces F_A " must be requested.

Periflex® Top Torque can be used in the temperature range from -50°C to $+80^{\circ}\text{C}$. The flexible element can reach higher temperatures than the ambient temperature as a result of damping work. When covering the coupling with a protective cover, this must be taken into account by ensuring adequate ventilation and heat dissipation.

Flexible couplings usually represent the safety breaking point of a drive train. Overloading the drive train therefore usually leads to failure of the flexible coupling elements. This behaviour is deliberate and protects the entire system from unforeseen damage. Any consequential damage resulting from this safety function of the coupling must be taken into account in advance by the plant designer and monitored or prevented with appropriate measures.

Use in potentially explosive environments

The coupling complies with the requirements of Directive 2014/34/EU and can be used as follows:

Device group II (Above ground application)

- Category 2G (Zone 1) and 3G (Zone 2) in atmospheres with combustible gases, mists and vapours or category 2D (Zone 21) and 3D (Zone 22) in combustible dust-air atmospheres
- Temperature category T4 for gases and vapours or a maximum surface temperature of 120°C for dust
- The ignition protection class of the coupling is "c". This means that the protective measures comply with DIN EN 13463-5 (Protection by constructional safety 'c')

Device group I (underground application up to shaft tyre size 426)

- Category M2 with a high degree of safety: in the event of an explosive atmosphere, the equipment must be able to be switched off via the system

The Periflex® Top Torque compliance with the requirements for each of these zones/categories is documented in the form of the following codes on our products:

Use in gas atmospheres:  II 2G c T4

Use in dust atmospheres:  II 2D c 120°C

Use underground:  I M2

Use in potentially explosive environments must be based on the request form annexed to this catalogue.

Stromag Periflex® Top Torque-Shaft Coupling

Classification rules

For a coupling to be accepted by a classification society, its rules must be observed. The coupling characteristics may differ from the definitions shown in this catalogue. The relevant prepared data sheets are available on request. Some classification societies prescribe fail-safe devices for ship propulsion main engines.

Instructions on choosing the coupling size

Static and dynamic characteristic values are available for Stromag Periflex® Top Torque Couplings. These help you to choose the correct coupling size for the specific drive application.

Versions with R-tyres have a lower torsional stiffness. Couplings with X-tyres are stiffer, but due to diagonally arranged fabric layers they are better suited for reverse operation or shock loads.

The key factors to consider when choosing a Periflex® Top Torque are the loads from transferred power and torsional vibrations. The value T_{KN} is to be used for stationary operating modes, while T_{Kmax} is to be used for non-stationary operating modes.

When selecting on the basis of the system torque, the application factors f_{ANW} must be taken into account. Stromag departments can provide support with the design, specifically in calculating the torsional vibrations. We therefore ask you to complete and return the question sheet annexed to this catalogue.

Application factor

If safety factors have not been considered when designing the plant, the following application factors (f_{ANW}) should be considered in the design phase:

Application factor f_{ANW}

I	II	III
1.25	1.5	2.0

To determine the application factor, the driven machines are divided into the following groups:

- I. Work machines with uniform power consumption, such as small machine tools with rotating main movement, small woodworking machines, small fans, small centrifugal pumps, generators, belt conveyors.
- II. Medium-duty work machines with non-uniform power consumption, such as diesel and gas engines, chain conveyors, crane trolleys, generators, elevators, looms, etc.
- III. Heavy-duty machines or with non-uniform power consumption, such as excavator drives, thrashing machines, heavy drilling rigs, paper calenders, centrifuges.

Stromag Periflex® Top Torque-Shaft Coupling

Assembly instructions and scope of delivery

To assemble the Periflex® Top Torque, mount the hubs (1,2) with pressure rings (3) on the shaft ends and align the system components.

The shaft tyre (4) is mounted on the hubs and secured with pressure rings (3) and screws (5).

The scope of delivery in the standard version includes:

- 1 = Hub
- 2 = Hub
- 3 = Pressure ring
- 4 = Shaft tyre
- 5 = Screws

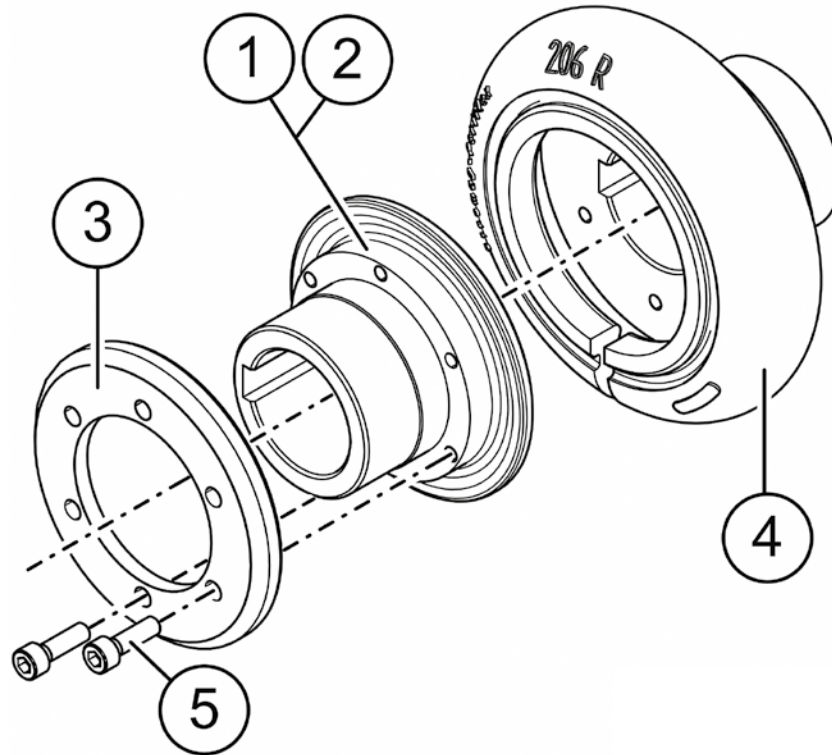

ELAST-0284

Storing flexible rubber elements

Flexible rubber elements retain their properties for several years if stored correctly. It is essential to protect the stored parts from oxygen, ozone, light, heat, moisture and solvents. Solvents, fuels, lubricants, chemicals, acids, disinfectants and similar substances must not be stored in the storage room. The storage temperature should not drop below +10°C and should not exceed +25°C.

All UV light sources are harmful and should be avoided. Ozone-generating devices such as light sources and electric motors must be kept away from the storage location. The relative humidity should not exceed 65%.

Further details can be found in the standards DIN 7716 and ISO 2230.

Stromag Periflex® Top Torque-Shaft Coupling

Assignment of Stromag Periflex® Top Torque Couplings to electric motors

Assignment of Periflex® Top Torque Couplings to three-phase asynchronous motors of gear sizes 56 to 315 with cage rotor according to EN 50347.

Motor size	Motor power at 3000 rpm (2-pole)		Coupling size PTT	Motor power at 1500 rpm (4-pole)		Coupling size PTT	Cylinder shaft D x L [mm]	
	P [kW]	T [Nm]		P [kW]	T [Nm]		3000 rpm	≤ 1500 rpm
56 M	0.09	0.3	86	0.06	0.4	86	9 x 20	
	0.12	0.4	86	0.09	0.6	86		
63 M	0.18	0.6	86	0.12	0.8	86	11 x 23	
	0.25	0.8	86	0.18	1.2	86		
71 M	0.37	1.2	86	0.25	1.6	86	14 x 30	
	0.55	1.8	86	0.37	2.4	86		
80 M	0.75	2.4	86	0.55	3.5	86	19 x 40	
	1.1	3.5	86	0.75	4.8	86		
90 S	1.5	4.8	86	1.1	7.0	86	24 x 50	
90 L	2.2	7.0	86	1.5	9.6	86	24 x 50	
100 L	3	9.6	104	2.2	14	104	28 x 60	
				3	19	104		
112 M	4	13	104	4	25	104	28 x 60	
132 S	5.5	18	104	5.5	35	104	38 x 80	
	7.5	24	104					
132 M	-	-	-	7.5	48	104	38 x 80	
160 M	11	35	136	11	70	136	42 x 110	
	15	48	136					
160 L	18.5	59	136	15	96	178	42 x 110	
180 M	22	70	178	18.5	118	178	48 x 110	
180 L	-	-	-	22	140	178	48 x 110	
200 L	30	96	178	30	191	211	55 x 110	
	37	118	178					
225 S	-	-	-	37	236	211	55 x 110	60 x 140
225 M	45	143	178	45	287	211	55 x 110	60 x 140
250 M	55	175	211	55	350	211	60 x 140	65 X 140
280 S	75	239	211	75	478	263	60 x 140	75 X 140
280 M	75	287	211	90	573	263	60 x 140	75 X 140
315 S	110	350	211	110	700	263	60 x 140	80 X 170
315 M	132	420	263	132	840	310	60 x 140	80 X 170

The assignment takes application factor II into account in normal load cases.

For systems with predominantly periodic excitations, the design must be in accordance with DIN 740 Part 2. Stromag departments can provide support with the design, specifically in calculating the torsional vibrations.

Stromag Periflex® Top Torque-Shaft Coupling

Assignment of Periflex® Top Torque Couplings to three-phase asynchronous motors of gear sizes 56 to 315 with cage rotor according to EN 50347.

Motor size	Motor power at 1000 rpm (6-pole)		Coupling size PTT	Motor power at 750 rpm (8-pole)		Coupling size PTT	Cylinder shaft D x L [mm]	
	P [kW]	T [Nm]		P [kW]	T [Nm]		3000 rpm	≤ 1500 rpm
56 M	-	-	-	-	-	-	9 x 20	
63 M	-	-	-	-	-	-	11 x 23	
71 M	-	-	-	-	-	-	14 x 30	
80 M	0.37 0.55	3.5 5.3	86 86	-	-	-	19 x 40	
90 S	0.75	7.2	86	-	-	-	24 x 50	
90 L	1.1	11	86	-	-	-	24 x 50	
100 L	1.5	14	104	0.75 1.1	10 14	104 104	28 x 60	
112 M	2.2	21	104	1.5	19	104	28 x 60	
132 S	3	29	104	2.2	28	104	38 x 80	
132 M	4 5.5	38 53	104 136	3	38	104	38 x 80	
160 M	7.5	72	136	4 5.5	51 70	136 136	42 x 110	
160 L	11	105	178	7.5	96	178	42 x 110	
180 M	-	-	-	-	-	-	48 x 110	
180 L	15	143	178	11	140	178	48 x 110	
200 L	18.5 22	177 210	178 211	15	191	211	55 x 110	
225 S	-	-	-	18.5	236	211	55 x 110	60 x 140
225 M	30	287	211	22	280	211	55 x 110	60 x 140
250 M	37	353	211	30	382	263	60 x 140	65 x 140
280 S	45	430	263	37	471	263	65 x 140	75 x 140
280 M	55	525	263	45	573	263	65 x 140	75 x 140
315 S	75	716	263	55	700	263	65 x 140	80 x 170
315 M	90	860	310	75	955	310	65 x 140	80 x 170

The assignment takes application factor II into account in normal load cases.

For systems with predominantly periodic excitations, the design must be in accordance with DIN 740 Part 2. Stromag departments can provide support with the design, specifically in calculating the torsional vibrations.

Stromag Periflex® Top Torque-Shaft Coupling

Output table, couplings with R tyres

Coupling size	Tyre	Nominal torque	Max. torque	Admissible alternating torque	Admissible speed	Admissible axial displacement	Axial stiffness
		T_{KN} Nm	T_{Kmax} Nm	T_{KW} Nm	n_{max} rpm	ΔK_a mm	C_a N/mm 2) 3)
86 R	201 R	35	75	15	5000	1.0	60
104 R	203 R	70	150	30	5000	1.0	110
136 R	206 R	135	300	55	5000	1.5	130
178 R	210 R	270	600	110	4000	2.0	120
211 R	214 R	545	1200	215	4000	2.5	150
263 R	218 R	1000	2400	400	3000	3.0	160
310 R	222 R	2200	4800	880	3000	3.5	180
370 R	225 R	3400	7500	1360	2500	4.5	400
402 R	426 R	5500	12000	2200	2300	5.0	340
450 R	828 R	8200	18000	3280	1800	5.5	250
550 R	1230 R	13700	30000	5480	1500	6.0	1000
700 R	1832 R	20500	45000	8200	1000	6.0	1800

1) At maximum speed

2) This value must be reduced at coupling temperatures higher than 30°C above the temperature factor (see page 21)

3) Material tolerances up to $\pm 15\%$ are possible

Stromag Periflex® Top Torque-Shaft Coupling

Admissible radial displacement	Radial stiffness	Admissible angular displacement	Torsional stiffness					Relative damping
			$C_{T \text{ dyn}}$ Nm/rad 2) 3)					
ΔK_r mm 1) 2)	C_r N/mm 2) 3)	ΔK_w ° 1) 2)	$0.0 \times T_{KN}$	$0.25 \times T_{KN}$	$0.5 \times T_{KN}$	$0.75 \times T_{KN}$	$1.0 \times T_{KN}$	ψ 3)
0.70	60	2.0	295	280	285	305	335	1.2
0.75	120	2.0	690	645	675	770	910	1.2
1.0	120	2.0	1100	1000	1100	1300	1650	1.2
1.3	110	2.0	2100	2050	2250	2650	3150	1.2
1.6	150	2.0	5000	4650	4950	5400	5950	1.2
2.1	150	2.0	6800	6200	7200	9900	15000	1.2
2.5	200	2.0	14000	13200	18200	28700	44500	1.2
3.0	400	2.0	22500	23000	33000	46000	61000	1.2
3.5	500	2.0	29000	28000	50000	84000	128000	1.2
3.7	400	2.0	29000	29000	52000	87000	132000	1.2
4.2	1200	2.0	41000	42000	71000	110000	154000	1.2
5.2	1500	2.0	134000	131000	143000	164000	192000	1.2

Stromag Periflex® Top Torque-**Shaft Coupling**

Output table, couplings with X tyres

Coupling size	Tyre	Nominal torque	Max. torque	Admissible alternating torque	Admissible speed	Admissible axial displacement	Axial stiffness
		T_{KN} Nm	T_{Kmax} Nm	T_{KW} Nm	n_{max} rpm	ΔK_a mm	C_a N/mm 2) 3)
86 X	201 X	35	75	15	5000	1.0	90
104 X	203 X	70	150	30	5000	1.0	140
136 X	206 X	135	300	55	5000	1.5	150
178 X	210 X	270	600	110	4000	2.0	150
211 X	214 X	545	1200	215	4000	2.5	80
263 X	218 X	1000	2400	400	3000	3.0	80
310 X	222 X	2200	4800	880	3000	3.5	100
370 X	225 X	3400	7500	1360	2500	4.5	400
402 X	426 X	5500	12000	2200	2300	5.0	400
450 X	828 X	8200	18000	3280	1800	5.5	300
550 X	1230 X	13700	30000	5480	1500	6.0	1000
700 X	1832 X	20500	45000	8200	1000	6.0	1800

1) At maximum speed

2) This value must be reduced at coupling temperatures higher than 30°C above the temperature factor (see page 21)

3) Material tolerances up to ± 15% are possible

Stromag Periflex® Top Torque-Shaft Coupling

Admissible radial displacement	Radial stiffness	Admissible angular displacement	Torsional stiffness					Relative damping
			$C_{T \text{ dyn}}$ Nm/rad 2) 3)					
ΔK_r mm 1) 2)	C_r N/mm 2) 3)	ΔK_w ° 1) 2)	$0.0 \times T_{KN}$	$0.25 \times T_{KN}$	$0.5 \times T_{KN}$	$0.75 \times T_{KN}$	$1.0 \times T_{KN}$	ψ 3)
0.70	150	2.0	290	320	440	580	740	1.1
0.75	250	2.0	1160	1280	1410	1570	1810	1.1
1.0	350	2.0	2230	2560	2810	3050	3300	1.1
1.3	300	2.0	4000	5250	5950	6350	6650	1.1
1.6	650	2.0	12000	14300	15450	16200	16600	1.1
2.1	900	2.0	14000	17750	19700	20900	21750	1.1
2.5	900	2.0	22000	31000	37300	41700	45200	1.1
3.0	2500	2.0	60000	78000	88000	93500	96500	1.1
3.5	1650	2.0	80000	93000	99000	102000	104000	1.1
3.7	1800	2.0	90000	85500	99500	127000	165500	1.1
4.2	3500	2.0	150000	135800	142300	161000	188500	1.1
5.2	4000	2.0	360000	321500	333000	369000	421000	1.1

Stromag Periflex® Top Torque-Shaft Coupling

Series

PTT

Standard design with variable hubs for shaft-shaft as well as for flanged shaft etc. connections.

Nominal torque from 35 to 20,500 Nm

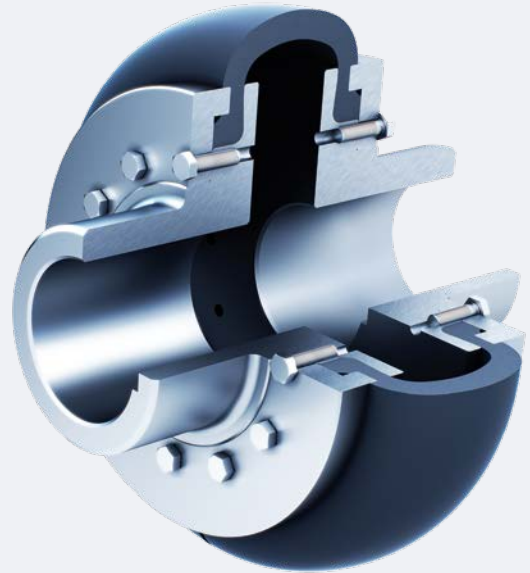

PTS

Short version of the shaft coupling.

The taper bushes allow quick and easy assembly and disassembly on a shaft.

Transmittable torque from 130 - 14,200 Nm

(depending on the taper bush used and parallel keyway inserted)

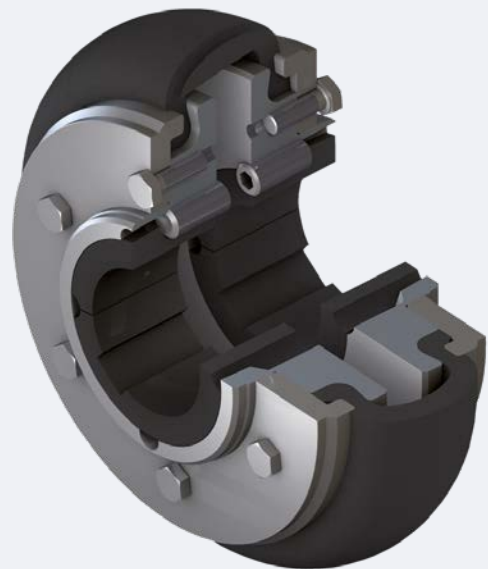

Stromag Periflex® Top Torque-Shaft Coupling

PTT Series

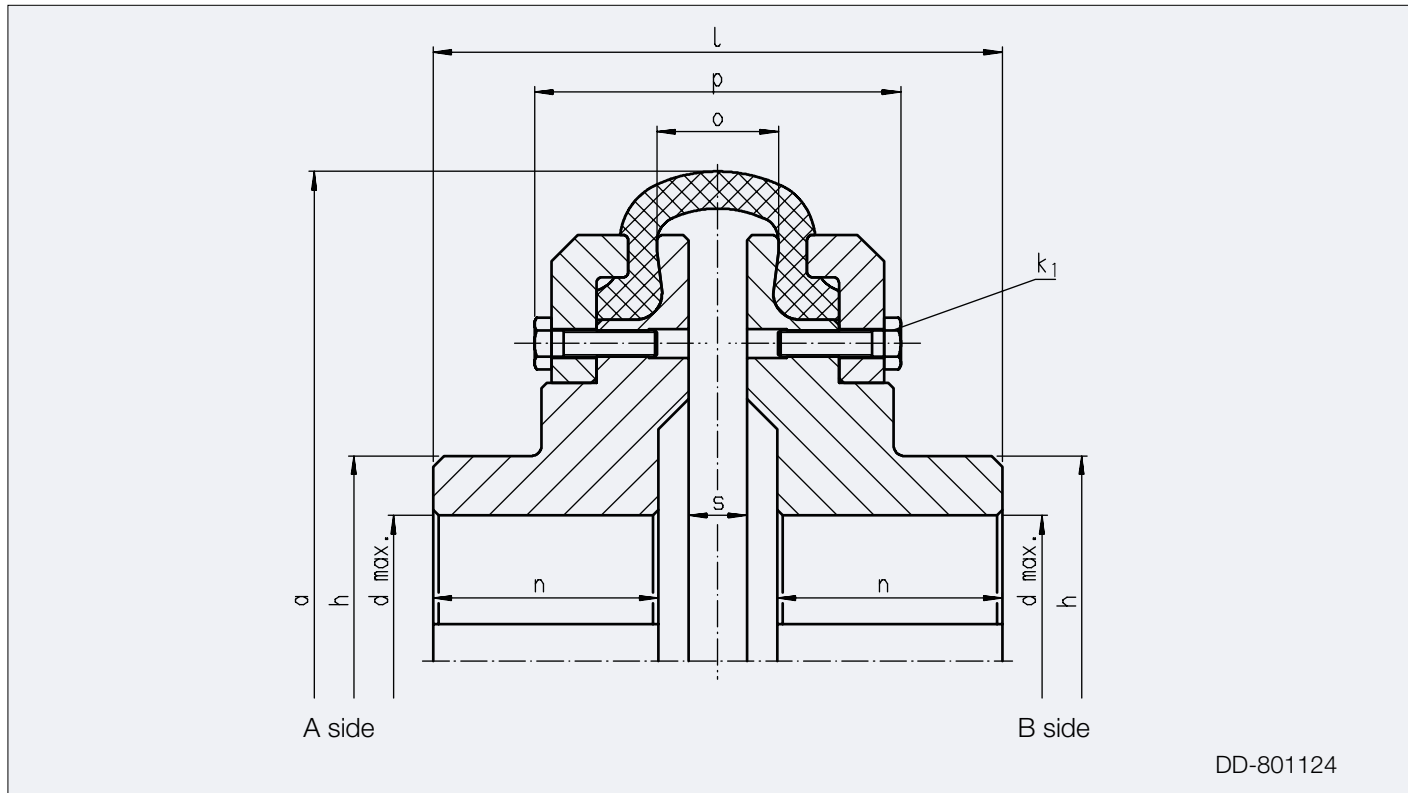

PTT...R Series												
Coupling size	86 R	104 R	136 R	178 R	211 R	263 R	310 R	370 R	402 R	450 R	550 R	700 R
Tyre	201 R	203 R	206 R	210 R	214 R	218 R	222 R	225 R	426 R	828 R	1230 R	1832 R
PTT...X Series												
Coupling size	86 X	104 X	136 X	178 X	211 X	263 X	310 X	370 X	402 X	450 X	550 X	700 X
Tyre	201 X	203 X	206 X	210 X	414 X	418 X	422 X	225 X	426 X	828 X	1230 X	1832 X
Nominal torque T_{kN} [Nm]	35	70	135	270	545	1000	2200	3400	5500	8200	13700	20500
Diameter [mm]												
a	86	104	136	178	210	263	310	370	402	450	550	700
d_{max}	24	30	42	55	65	85	110	110	120	130	150	180
h	34	43	58	76	92	120	154	155	170	185	210	255
Screws K_1	4x M5	4x M6	6x M6	6x M8	6x M10	6x M10	8x M10	8x M10	12x M12	12x M16	12x M16	12x M20
Length [mm]												
l	60	70	110	130	160	190	240	235	294	340	480	530
n	26	31	51	55.5	70	84.5	110	106.5	135	153	198	217
o	16	16	18	35	38	44	42	46	50	70	120	150
$p_{unclamped}$	60	85	77	103	112	130	146	160	163	197	296	380
s	8	8	8	19	20	21	20	22	24	34	84	96
Mass moment of inertia J [kgm ²]												
$J_{A \text{ side}}^*)$	0.00025	0.00050	0.0017	0.0064	0.0173	0.0596	0.151	0.379	0.558	0.894	1.999	6.274
$J_{B \text{ side}}^*)$	0.00025	0.00050	0.0017	0.0064	0.0173	0.0596	0.151	0.379	0.558	0.894	1.999	6.274
Mass m [kg] *)	0.81	1.21	2.55	5.24	9.91	20.4	35.9	59.8	78.1	105	172	340

*) at maximum bore diameter

Stromag Periflex® Top Torque-Shaft Coupling

PTS Series

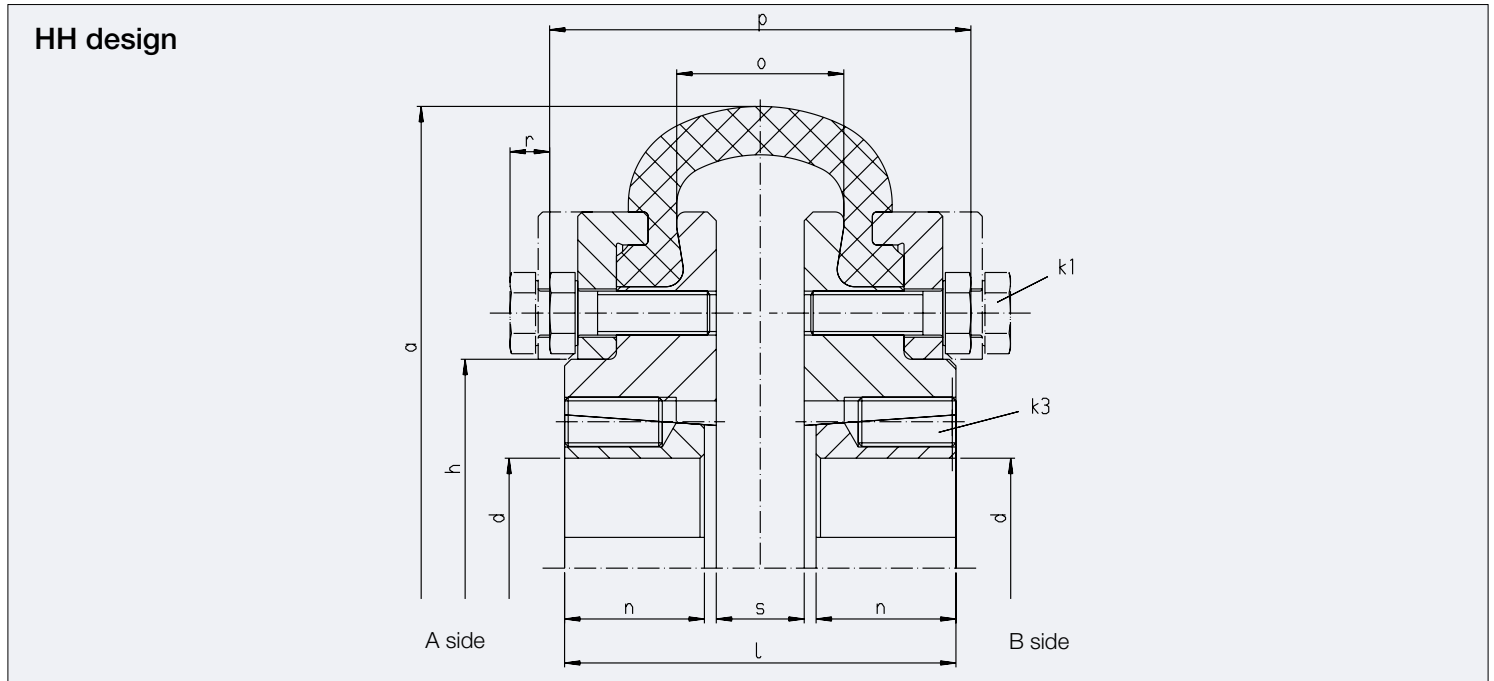

PTS...R Series								
Coupling size	104 R		136 R		178 R		211 R	
Tyre	203 R		206 R		210 R		214 R	
PTS...X Series								
Coupling size	104 X		136 X		178 X		211 X	
Reifen	203 X		206 X		210 X		414 X	
Design	HH	GG	HH	GG	HH	GG	HH	GG
Taper bush	1008	1008	1108	1210	1615	2012	2012	2517
max. Torque T_{Smax} [Nm]	130	130	140	300	480	800	800	1300
Diameter [mm]								
a	104	104	136	136	178	178	211	211
d_{max}	24	24	25	30	40	50	50	60
h	43	43	59	59	77	77	95	98
Screws K_1	4x M6		6x M6		6x M8		6x M10	
Screws K_3 (BSW)	2x 1/4"	2x 1/4"	2x 1/4"	2x 3/8"	2x 3/8"	2x 7/16"	2x 7/16"	2x 1/2"
Length [mm]								
l	53	53	53	59	95	86	89	96
n	20	20	20	25.5	38	30.5	30.5	43
o	16	16	18	18	35	35	38	38
p	54.4	54.4	62.8	62.8	87.6	90	95.8	103
r	3.4	3.4	6.6	6.6	8.7	7.5	9	8
s	8	8	8	8	19	6	20	7
Mass moment of inertia J [kgm ²]								
J_A side *)	0.0005	0.0005	0.0016	0.0016	0.0061	0.0061	0.0154	0.0154
J_B side *)	0.0005	0.0005	0.0016	0.0016	0.0061	0.0061	0.0154	0.0154
Mass m [kg] *)	1.05	1.06	2.14	1.97	4.74	4.74	7.89	7.89

*) Without taper bushes

Stromag Periflex® Top Torque-Shaft Coupling

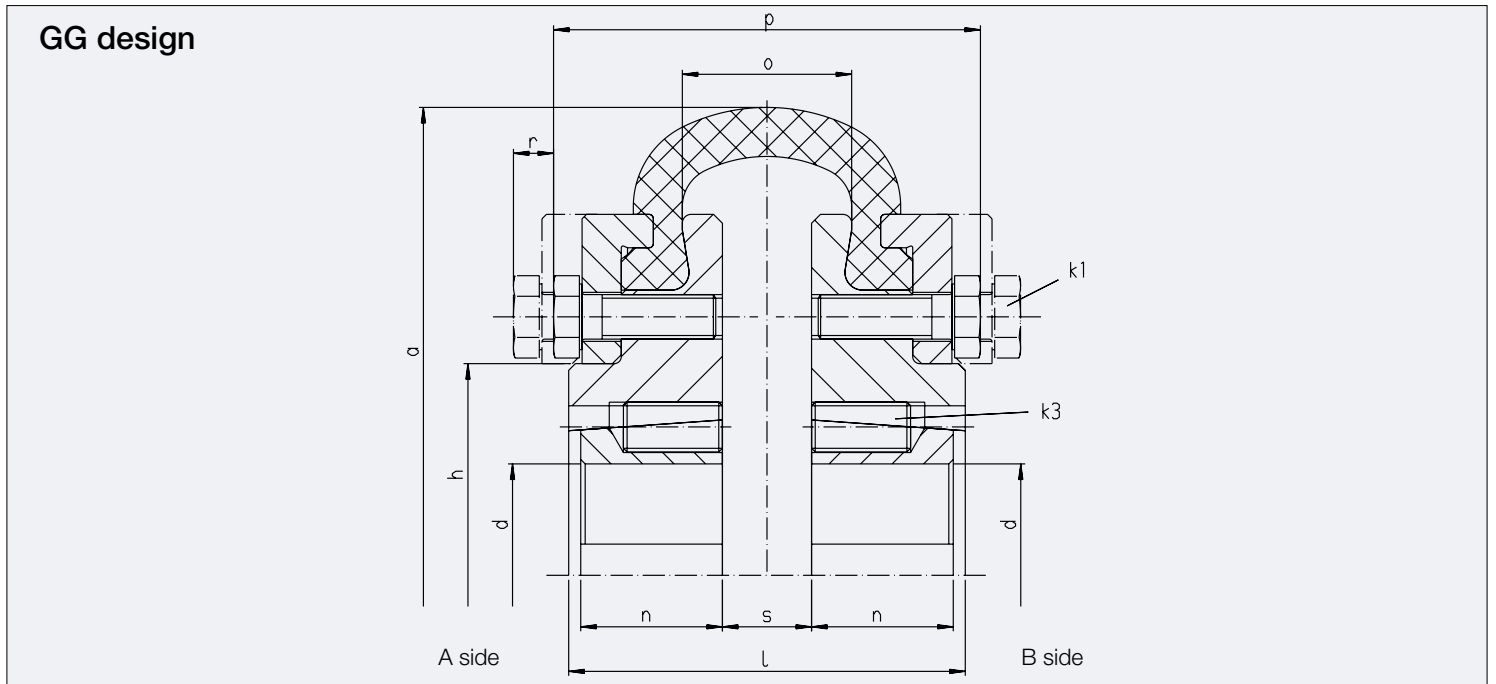

263 R		310 R		370 R		402 R		450 R		550 R	
218 R		222 R		225 R		426 R		828 R		1230 R	
263 X		310 X		370 X		402 X		450 X		550 X	
418 X		422 X		225 X		426 X		828 X		1230 X	
HH	GG	HH	GG	HH	GG	HH	GG	HH	GG	HH	GG
2517	3020	3030	3525	3525	3525	3525	4030	4030	4535	4545	5050
1300	2400	2700	4800	5050	5050	5050	8700	8700	12400	12400	14200
263	263	310	310	370	370	402	402	450	450	550	550
60	75	125	95	95	95	95	115	115	125	115	125
122	122	158	158	210	210	235	235	220	220	250	250
6x M10		8x M10		8x M10		12x M12		12x M16		12x M16	
2x 1/2"	2x 5/8"	2x 5/8"	3x 1/2"	3x 1/2"	3x 1/2"	3x 1/2"	3x 5/8"	3x 5/8"	3x 3/4"	3x 3/4"	3x 7/8"
111	123	174	148	150	150	152	176	186	214	312	340
43	50.8	76	64	64	64	64	76	76	89	114	127
44	44	42	42	46	46	50	50	70	70	120	120
110.1	110.1	121	121	133.4	133.4	139.8	139.8	178.6	178.6	262.4	262.4
11.4	11.4	14.4	14.4	14.7	14.7	14.6	14.6	15.7	15.7	21.8	21.8
21	21	20	20	22	22	24	24	34	34	84	84
0.0562	0.0540	0.141	0.131	0.362	0.362	0.523	0.518	0.831	0.825	1.885	1.871
0.0562	0.0540	0.141	0.131	0.362	0.362	0.523	0.518	0.831	0.825	1.885	1.871
17.6	15.6	33.0	27.3	52.0	52.0	65.2	62.5	86.5	83.7	148	144

Stromag Periflex® Top Torque-Shaft Coupling

Characteristics of Periflex® Top Torque coupling

T_{KN}	
<p>The nominal torque of the coupling can be permanently transferred over the entire admissible speed range.</p> <p>It must not exceed the nominal torque T_N of the system.</p>	$T_{KN} \geq T_N$
T_{Kmax}	
<p>The maximum torque T_{Kmax} of the coupling can be endured as a peak load and must not be exceeded by peak torques T_{max} when the system is operating in normal, transient conditions.</p> <p>Normal transient operating conditions of a system are unavoidable and occur repeatedly (such as start and stop procedures, resonance passes, switchovers, accelerations, etc.).</p> <p>The maximum torque of the coupling can be tolerated for a short period of time, i. e. without thermal influences on the coupling, as a swelling or alternating load.</p> <p>Overloading the Stromag Periflex® Top Torque coupling with the system's irregular, non-stationary peak torques shortens the service life.</p> <p>Irregular, transient peak torques of a system can be avoided and are not part of the planned operating pattern (for example, emergency stop, synchronisation failure, short circuit, etc.).</p>	$T_{Kmax} \geq T_{max}$
T_{Kw}	
<p>The admissible continuous alternating torque indicates the amplitude of the continuously permissible periodic torque fluctuation.</p> <p>This torque may be superimposed on a base load equal to T_{KN}.</p>	
ΔK_a	
<p>Admissible axial displacement of the coupling. The axial displacement ΔW_a of the shafts must be smaller than ΔK_a.</p>	$\Delta K_a \geq \Delta W_a$
ΔK_r	
<p>Admissible radial displacement of the coupling. The radial displacement ΔW_r of the shafts must be smaller than ΔK_r.</p> <p>The specified values for ΔK_r are related to the maximum speed of the coupling. The admissible radial displacement must be reduced at ambient temperatures above 30°C by the temperature factor S_{9Kr}; see diagram on page 21.</p>	$\Delta K_r \geq \Delta W_r$ $\Delta K_r(T_u) = \frac{\Delta K_r}{S_{9Kr}}$
ΔK_w	
<p>Admissible angular displacement of the coupling. The angular displacement of the shafts ΔW_w must be smaller than ΔK_w.</p> <p>The specified value for ΔK_w refers to the maximum speed of the coupling.</p> <p>However, this value may only be fully used if there are no further radial displacements.</p> <p>The admissible angular displacement must be reduced at ambient temperatures above 30°C by the temperature factor S_{9Kw}; see diagram on page 21.</p>	$\Delta K_w \geq \Delta W_w$ $\Delta K_w(T_u) = \frac{\Delta K_w}{S_{9Kw}}$

Stromag Periflex® Top Torque-Shaft Coupling

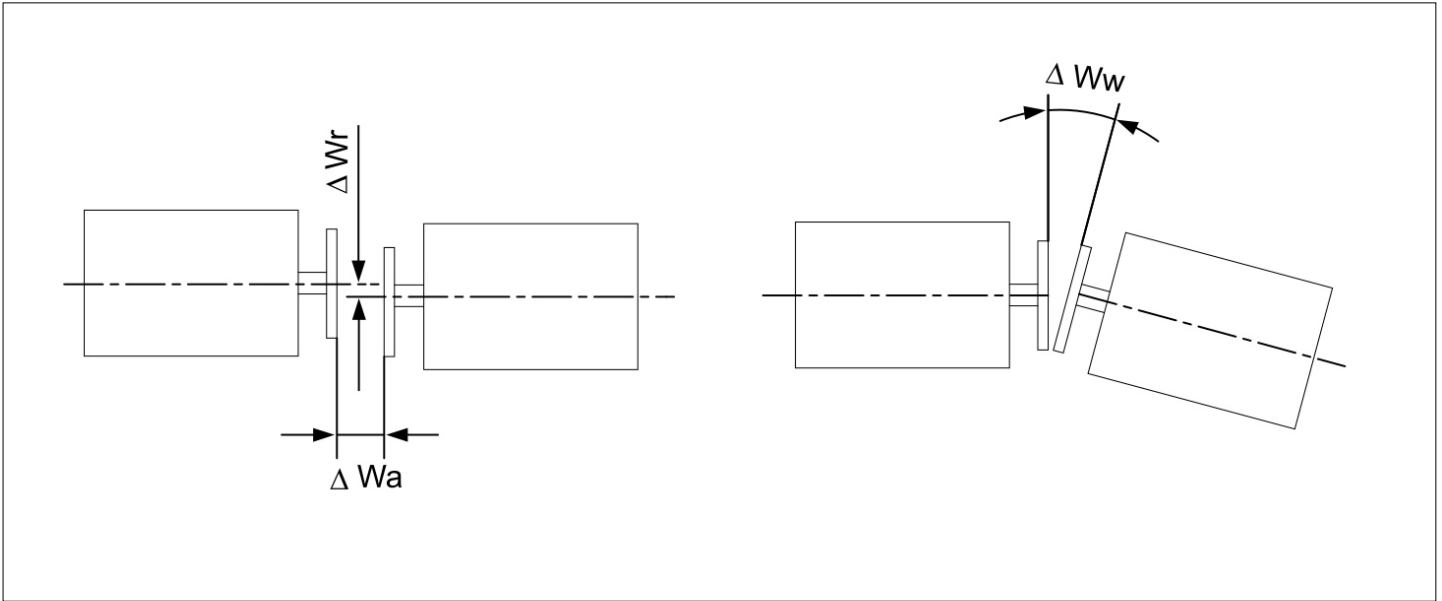

C_a

The axial stiffness indicates the axial restoring force after axial displacement. At ambient temperatures above 30°C, the specified values must be reduced by temperature factor S_{9C} ; see diagram on page 21.

$$C_a(T_U) = \frac{C_a}{S_{9C}}$$

C_r

The radial stiffness indicates the radial restoring force after radial displacement. For ambient temperatures above 30°C, the indicated values must be reduced by the temperature factor S_{9C} ; see diagram on page 21.

$$C_r(T_U) = \frac{C_r}{S_{9C}}$$

C_{Tdyn}

The dynamic torsional stiffness indicates the relationship of a torque amplitude to the rotational angle amplitude during an oscillation process.

With Periflex® Top Torque, the C_{Tdyn} value is not constant (progressive characteristic) over the coupling torque and also changes with the amplitude, frequency and temperature of the tyre.

The specifications for C_{Tdyn} are based on an alternating torque of $0.25 \times T_{KN}$, a frequency of 10 Hz and an ambient temperature T_U below 30°C.

For higher ambient temperatures, the indicated values must be reduced by the temperature factor S_{9C} ; see diagram on page 21.

$$C_{Tdyn} = \frac{T_{el}}{\varphi_w}$$

$$C_{Tdyn}(T_U) = \frac{C_{Tdyn}}{S_{9C}}$$

Stromag Periflex® Top Torque-Shaft Coupling

Characteristics of Periflex® Top Torque coupling

Ψ

The relative damping is a measure of the coupling's ability to convert part of the oscillation energy into heat.

The relative damping can be determined with the damping loop (hysteresis loop).

The area A_D is a measure of the damping work W_D during an oscillation cycle.

The area A_{el} represents flexible deformation work W_{el} at a given load.

The specifications for Ψ are based on a coupling torque of $0.75 \times T_{KN}$, an alternating torque of $0.25 \times T_{KN}$ and a frequency of 10 Hz with a coupling in warm operating conditions and a surface temperature of approximately 30°C.

$$\Psi = \frac{W_D}{W_{el}} = \frac{A_D}{A_{el}}$$

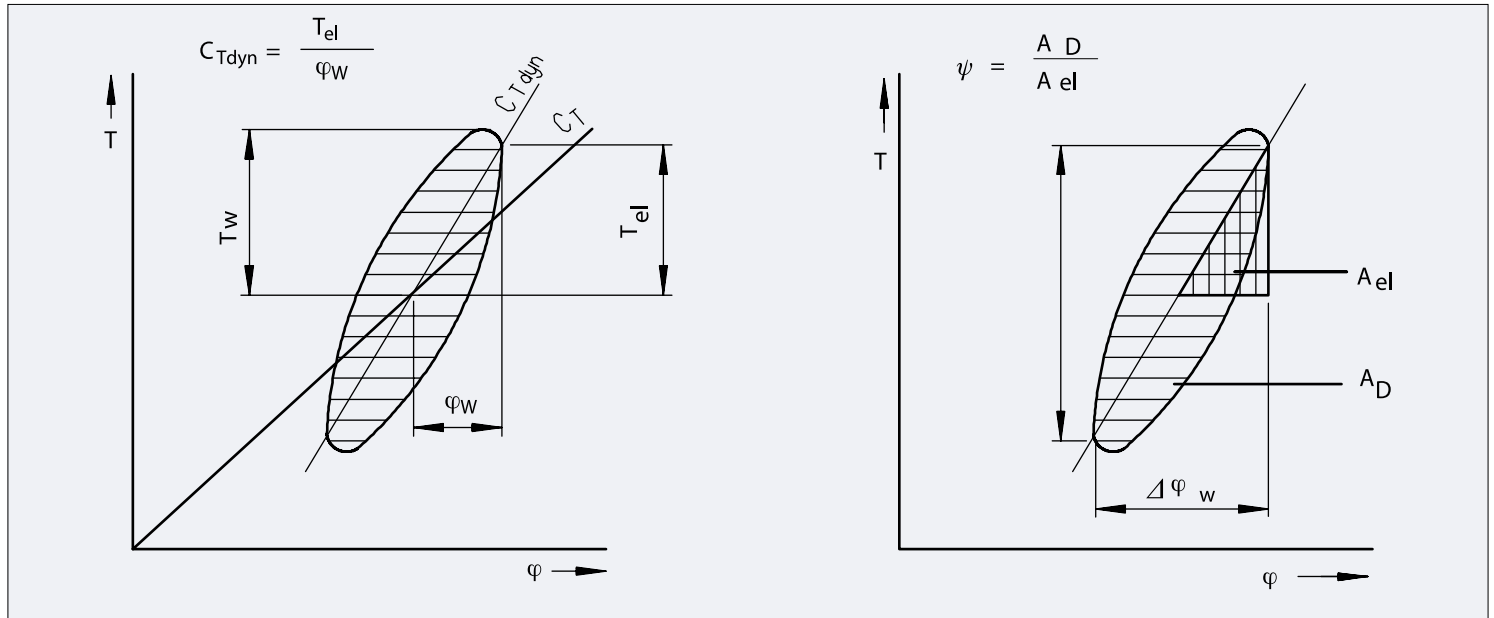

Stromag Periflex® Top Torque-**Shaft Coupling**

$S_{\theta Kr}$, $S_{\theta Kw}$ and $S_{\theta C}$

Temperature factors should take into account the decrease in the physical properties of flexible rubber materials due to excessive heating.

The coupling temperature is determined by the ambient temperature as well as internal heating caused by internal material friction in the rubber volume as a result of alternating torques and alternating loads due to shaft displacement.

At higher ambient temperatures, the coupling characteristics ΔK_r and ΔK_w must be reduced by the temperature factors $S_{\theta Kr}$ and $S_{\theta Kw}$. C_{Tdyn} , C_r and C_a are set to a value that is reduced by the temperature factor $S_{\theta C}$ due to heating.

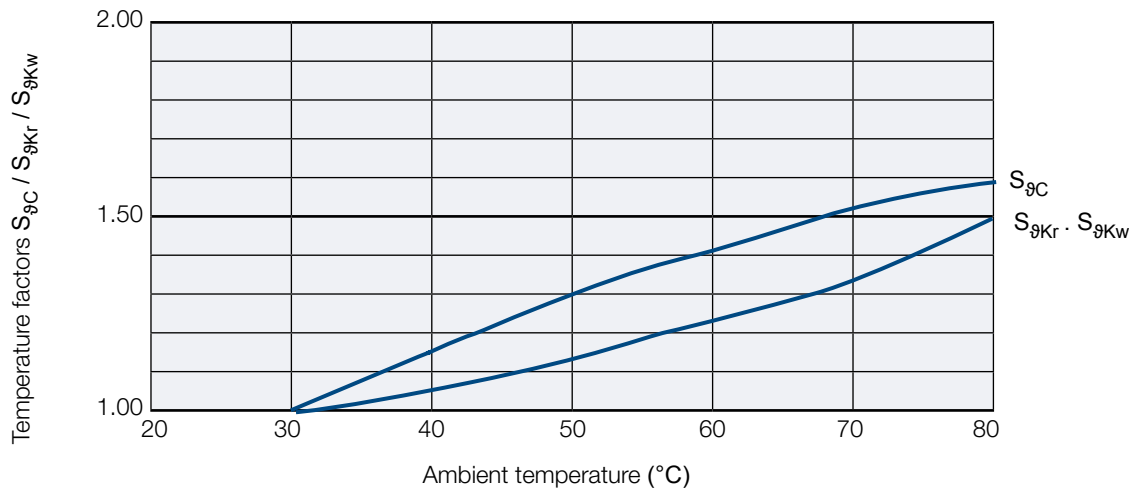

Stromag Periflex® Top Torque-**Shaft Coupling**

Coupling design, question sheet

Main engine		
Engine type (electric, internal combustion engine, etc.)		
Motor type (make, type)		
Motor installation (rigid, flexible)		
Engine housing (SAE)		
Flywheel centring diameter		mm
Power rating		kW
Nominal speed		rpm
Speed range		rpm
Nominal torque		Nm
Maximal torque (tilting moment)		Nm
Moment of inertia		kgm ²
Number of hourly starts or reversals		
Gear		
Gear ratio		
Moment of inertia		kgm ²
Driven side		
Type (generator, fan, compressor, fixed or variable pitch propeller)		
Main or auxiliary drive		
Type of construction (free-standing or flange-mounted)		
Moment of inertia		kgm ²
Coupling		
Application site in the drive train (please enclose schematic sketch)		
Bore dimensions for coupling hub		mm
Ambient temperature		°C, °K
Classification society		

Stromag Periflex® Top Torque-Shaft Coupling

Use in potentially explosive environments, question sheet

Field of application		<input type="radio"/>	Group II (above ground application)
Potentially explosive atmosphere of air with		<input type="radio"/>	Gas
		<input type="radio"/>	Dust
Use in zone (category)	Gas	<input type="radio"/>	Zone 1 (category 2G)
		<input type="radio"/>	Zone 2 (category 3G)
	Dust	<input type="radio"/>	Zone 21 (category 2D)
		<input type="radio"/>	Zone 22, conductive (category 2D)
		<input type="radio"/>	Zone 22, insulating (category 3D)
Temperature class for gas atmosphere	Gas	<input type="radio"/>	T1
		<input type="radio"/>	T2
		<input type="radio"/>	T3
		<input type="radio"/>	T4
Maximum admissible surface temperature	Dust	<input type="radio"/>	120°C
		<input type="radio"/>	< 120°C
		<input type="radio"/>	-20°C to +40°C
Ambient temperature		<input type="radio"/>	Deviating ambient temperatures only with restrictions

Stromag Facilities

Europe

Germany

Hansastraße 120
59425 Unna - Germany
+49 (0) 23 03 102 0

*Clutches & Brakes, Couplings,
Geared Cam Limit Switches, Discs,
Wind Brakes*

Dessauer Str. 10
06844 Dessau-Roßlau - Germany
+49 (0) 340 2190 0

Electromagnetic Clutches & Brakes

France

Avenue de l'Europe
18150 La Guerche sur L'Aubois - France
+33 (0)2 48 80 72 72

Disc Brakes & Drum Brakes

Great Britain

Amphill Road
Bedford, MK42 9RD - UK
+44 (0)1234 324347

*Electromagnetic Clutches & Brakes,
Industrial Caliper Brakes*

North America

USA

31 Industrial Park Road
New Hartford, CT 06057 - USA
860-238-4783

Electromagnetic Clutches & Brakes

300 Indiana Highway 212
Michigan City, IN 46360 – USA
219-874-5248

Couplings

2800 Fisher Rd.
Wichita Falls, TX
940-723-3400

*Geared Cam Limit Switches,
Industrial Caliper & Drum Brakes*

Asia Pacific

China

T40B -5, No. 1765 Chuan Qiao Road
Pudong 201206, Shanghai - China
Tel +86 21-60580600

*Clutches & Brakes, Electromagnetic
Clutches & Brakes, Couplings, Industrial
Caliper & Drum Brakes, Discs, Geared
Cam Limit Switches, Wind Brakes*

India

Gat No.: 448/14, Shinde Vasti, Nighoje
Tal Khed, Pune- 410 501
+91 2135 622100

*Clutches & Brakes, Electromagnetic
Clutches & Brakes, Couplings, Industrial
Caliper & Drum Brakes, Discs,
Geared Cam Limit Switches, Wind Brakes*

The Brands of Altra Industrial Motion

Couplings

Ameridrives
www.ameridrives.com

Bibby Turboflex
www.bibbyturboflex.com

Guardian Couplings
www.guardiancouplings.com

Huco
www.huco.com

Lamiflex Couplings
www.lamiflexcouplings.com

Stromag
www.stromag.com

TB Wood's
www.tbwoods.com

Geared Cam Limit Switches

Stromag
www.stromag.com

Electric Clutches & Brakes

Inertia Dynamics
www.idicb.com

Matrix
www.matrix-international.com

Stromag
www.stromag.com

Warner Electric
www.warnerelectric.com

Linear Products

Warner Linear
www.warnerlinear.com

Engineered Bearing Assemblies

Kilian
www.kilianbearings.com

Heavy Duty Clutches & Brakes

Industrial Clutch
www.indclutch.com

Twiflex
www.twiflex.com

Stromag
www.stromag.com

Svendborg Brakes
www.svendborg-brakes.com

Wichita Clutch
www.wichitaclutch.com

Belted Drives

TB Wood's
www.tbwoods.com

Gearing

Bauer Gear Motor
www.bauergears.com

Boston Gear
www.bostongear.com

Delroyd Worm Gear
www.delroyd.com

Nuttall Gear
www.nuttallgear.com

Overrunning Clutches

Formsprag Clutch
www.formsprag.com

Marland Clutch
www.marland.com

Stieber
www.stieberclutch.com

Neither the accuracy nor completeness of the information contained in this publication is guaranteed by the company and may be subject to change in its sole discretion. The operating and performance characteristics of these products may vary depending on the application, installation, operating conditions and environmental factors. The company's terms and conditions of sale can be viewed at <http://www.altramotion.com/terms-and-conditions/sales-terms-and-conditions>. These terms and conditions apply to any person who may buy, acquire or use a product referred to herein, including any person who buys from a licensed distributor of these branded products.

©2018 by Stromag LLC. All rights reserved. All trademarks in this publication are the sole and exclusive property of Stromag LLC or one of its affiliated companies.